

We · support · the  
i n n o v a t i o n s · o f · c u s t o m e r s

# Leak - Proof Flow & Control Solution Partner

The Best Partner  
for Value Creation

**S-LOK<sup>®</sup>** Ball & Plug Valves



# Ball Valves

## *SBV, SFBV SERIES*

**SBV10** Series  3~4

**SBV30** Series  5~9

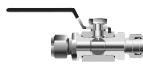
**SBV60** Series  10~13

**SFBV60** Series  14~17

# Trunnion Ball Valves

## *STBV SERIES*

**STBV** Series  18~21

# Ball Valves for DIN Standard

## *SDBV SERIES*

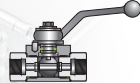
**SDBV** Series  22~24

# Plug Valves

## *SPV SERIES*

**SPV** Series  25~27



## SBV10 Series For working pressure up to 1000 psig(69bar)



### Features

- Compact design with hexagon bar-stock for high integrity.
- Working pressure up to 1000psig (69bar) at 100°F (38°C).
- Low torque quarter turn actuation.
- Size range of from 1/4" to 1" tubing and piping.
- Various end connections : reliable S-LOK, NPT & ISO male & female.
- Butterfly handle is available as option.

### Pressure-Temperature Ratings

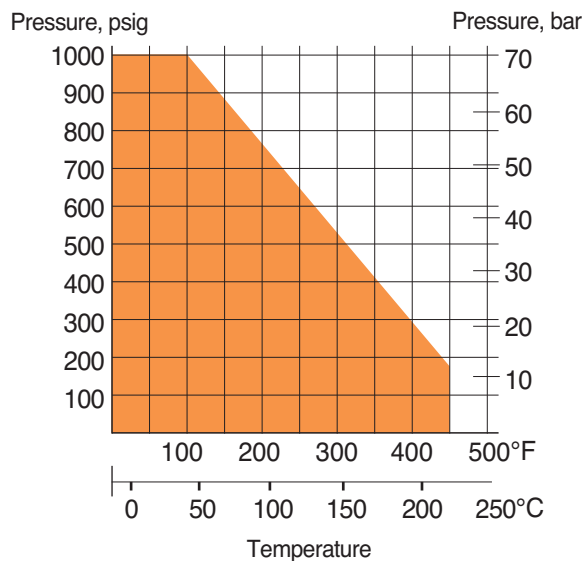

### Applications

- Water, Oil, Gas.
- Petrochemical Plants.
- Steel mills.
- Heavy Vehicles.

### Factory Test

- Every valve is factory tested with Nitrogen @ 1000psig (69bar) for leakage at the seat to a maximum allowable leak of 0.1sccm.
- The stem packing is tested for no detectable leakage.

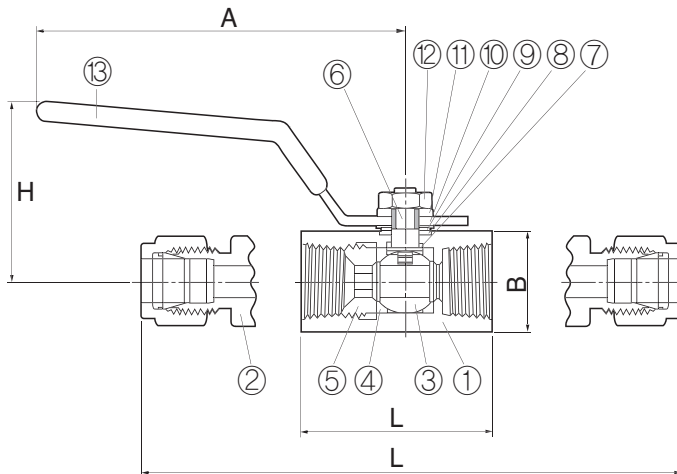

Item	Description	Material/ASTM Specification	
		S316	Brass
1	Body	S316/A479, A276	Brass/B16
2	End Connector	S316/A479, A276	Brass/B16
3	Ball	S316/A479, A276	
4	Seat	Reinforced PTFE	
5	Insert	S316/A479, A276	
6	Stem	S316/A479, A276	
7	Lower Packing	Reinforced PTFE	
8	Upper Packing	Reinforced PTFE	
9	Grand	S304	
10	Grand Washer	S304	
11	Spring Washer	S304	
12	Lock Nut	S304	
13	Handle	S304 with PVC Coating	

### Ordering Information and Dimensions

Basic Ordering Number	Orifice mm(in)	Cv	End Connections Inlet/Outlet	Dimensions (mm)			
				L	H	A	B
SBVA	S-6M	5.0	1.25 6mm S-LOK	79	31	55	17
	S-4T		1.25 1/4" S-LOK				
	F-4N		1.35 1/4" Female NPT				
SBVB	S-10M	7.5	2.60 10mm S-LOK	90	40	78	22
	S-6T		2.50 3/8" S-LOK				
	F-6N		2.60 3/8" Female NPT				
SBVC	S-12M	9.0	9.25 12mm S-LOK	98	42	78	27
	S-8T		9.25 1/2" S-LOK				
	F-8N		9.25 1/2" Female NPT				
SBVD	S-16M	12.5	10.60 16mm S-LOK	108	51	96	32
	S-10T		10.60 5/8" S-LOK				
	F-12N		12.65 3/4" Female NPT				
	S-12T		12.65 3/4" S-LOK				
SBVE	S-16T	16.0	17.35 1" S-LOK	133	55	96	38
	F-16N		17.35 1" Female NPT				

### Ordering Information

Select valve ordering number, and applicable options.

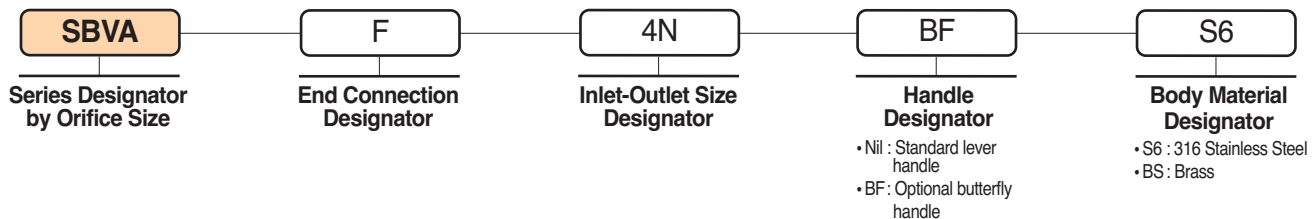

#### SAFETY in VALVE SELECTION

The selection of a valve for any application or system design must be considered to ensure safe performance. Valve function, valve rating, material compatibility, proper installation, operation and maintenance remain the sole responsibility of the system designer and the user.

**HANSUN ENGINEERING** accepts no liability for any improper selection, installation, operation or maintenance.

## SBV30 Series For working pressure up to 3000 psig(206bar)

- 1. Handle with Arrow**  
indicates flow direction.  
allows quick operation to open and close.
- 2. Panel Mounting Nut**  
allow easy installation.
- 3. Variety of End Connections**  
include fractional/metric S-LOK tube fittings,  
NPT female, ISO female threads.
- 4. One-piece body**  
reduces the number of potential leak points.
- 5. Orifice**  
is optimized design for minimum pressure drop.
- 6. Packing Bolt**  
allows easy packing adjustment with valve in-line.

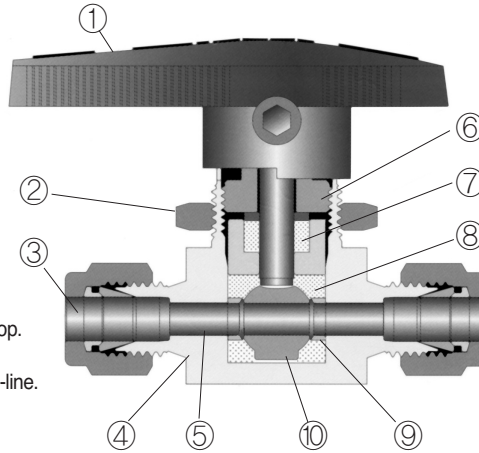

- 7. PTFE Packing**  
is supported by top and bottom glands.
- 8. Encapsulating Ball Seats**  
virtually allow no dead volume.  
are uniformly forced to form tight seals  
against ball and body cavity.
- 9. Support rings and discs**  
retains the capsule packing and prevent cold flow.
- 10. Integral Ball-Stem**  
is machined from one piece bar stock.  
is best suited to encapsulate ball seats.



### Features

- Pressure rating up to 3000psig(206bar) @70°F(21°C).
- Temperature rating from 50°F(10°C) to 150°F(65°C) with standard PTFE seat and packing.
- Choice of materials : Standard S316 and available in alloy 400 and Brass.
- Vent to atmosphere available.
- Every valve is 100% factory tested with the Nitrogen @1000psi (69bar).

### Technical Data

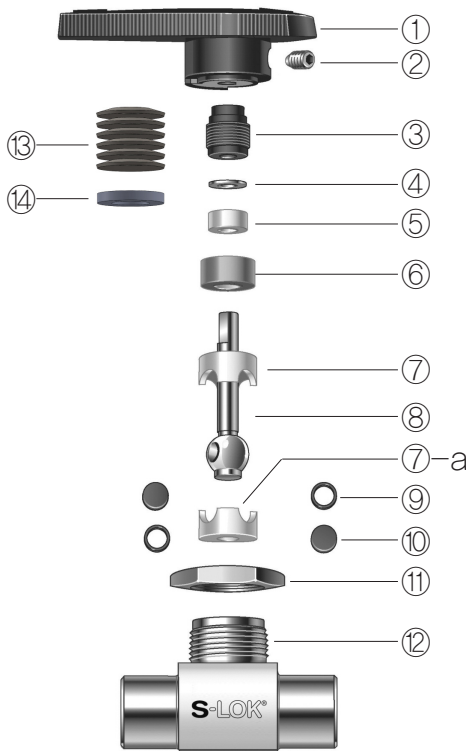

### Materials of construction

Description	Grade / ASTM Specification	
	Valve Body Materials	
	S316	Brass
1 Handle	Black Nylon	
2 Set screw	17-4PH/A564	
3 Packing bolt	S316/A479, A276	Brass/B16
4 Upper grand	S316/A479, A276	
5 Packing	PTFE/D1710	
6 Lower grand	S316/A479, A276	Brass/B16
7 & 7-a Upper&Lower Ball seat	PTFE/D1710 (standard) PFA (Option)	
8 Ball stem	S316/A479, A276	
9 Support rings	S316 (Fluorocarbon-coated)	
10 Side discs		
11 Panel nut	S316 /A479, A276	Brass/B16
12 Body		
13 Packing spring	17-4PH / A693	
14 Packing grand	S316 / A276	

### • Pressure Rating with standard PTFE & PFA seat

Valve Designator	Straight 2-way	Angle 2-way	Switching 3-way	Temperature Range	
				PTFE	PFA
SBV 1			2500psig (172bar)		
SBV 2	3000psig (206bar)		2500psig (172bar)	50°F to 150°F (10°C to 65°C)	-65°F to 150°F (-54°C to 65°C)
SBV 3			1500psig		
SBV 4			(103bar)		

### 2-Way (Shut-Off Valve)

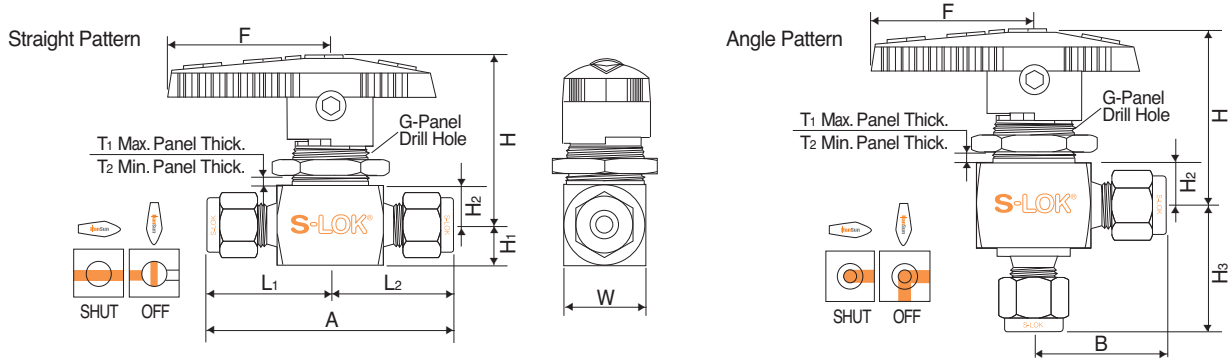

### Ordering Information and Dimensions

Basic Ordering Number	Orifice		Cv		End Connections		Dimensions (mm)											
	mm	inch	Inline	Angle	Inlet	Outlet	A	L1	L2	H3	H2	H1	F	T1	T2	G	H	W
SBV1	S-1T	1.3	0.052	0.1	-	1/16"	S-LOK	42.7	21.3	-	8.6	7.1	28.4	6.4	2.0	15.1	34.5	14.7
	S-2T	2.4	0.093	0.2	0.15	1/8"	S-LOK	51.1	25.6	24.6								
	S-3M			0.2	0.15	3mm	S-LOK	51.1	25.6	24.6								
	S-4T	3.2	0.125	0.6	0.35	1/4"	S-LOK	56.1	28.1	27.2								
	S-6M			0.6	0.35	6mm	S-LOK	56.1	28.1	27.2								
	F-2N			0.5	0.3	1/8"	Female NPT	41.1	20.6	20.6								
SBV2	S-4T	4.8	0.187	1.4	0.9	1/4"	S-LOK	59.9	30.0	29.7	11.2	9.7	38.9	4.8	2.5	19.8	39.6	19.8
	S-6T			1.5	0.9	3/8"	S-LOK	65.5	32.8	32.8								
	S-6M			1.4	0.9	6mm	S-LOK	60.7	30.4	29.7								
	S-8M			1.5	0.9	8mm	S-LOK	62.5	31.2	30.5								
	F-2N			1.2	0.7	1/8"	Female NPT	50.8	25.4	25.4								
	F-4N			0.9	0.75	1/4"	Female NPT	52.3	26.2	26.2								
	M-4N			1.2	0.75	1/4"	Male NPT	50.8	25.4	26.2								
	F-4R			0.9	0.75	1/4"	ISO Female Tapered	52.3	26.2	-								
SBV3	S-6T	7.1	0.281	6.0	2.0	3/8"	S-LOK	77.5	38.8	36.3	14.2	14.2	50.8	9.5	3.0	28.6	52.6	28.4
	S-10M			6.0	2.0	10mm	S-LOK	78.0	38.9	36.9								
	F-4N			3.0	1.7	1/4"	Female NPT	63.5	31.8	31.8								
	F-6N			2.6	1.5	3/8"	Female NPT	63.5	31.8	31.8								
	F-6R			2.6	1.5	3/8"	ISO Female Tapered	63.5	31.8	-								
SBV4	S-8T	10.3	0.406	12.0	4.6	1/2"	S-LOK	99.6	49.8	44.2	17.5	17.5	76.2	9.5	3.0	38.1	61.7	38.1
	S-12T			6.4	3.8	3/4"	S-LOK	99.6	49.8	44.2								
	S-12M	9.5	0.375	12.0	4.6	12mm	S-LOK	99.6	49.8	44.2								
	F-8N	10.3	0.406	6.3	3.5	1/2"	Female NPT	79.2	39.6	39.6								
	F-8R			6.3	3.5	1/2"	ISO Female Tapered	79.2	39.6	-								

All dimensions shown are for reference only and are subject to change. Dimensions with S-LOK nuts are in finger-tight position. Patterns : To order angle pattern, use-A as a suffix to the basic ordering number. Example : SBV1-S-4T-A-S6

### • Flow Rate

Pressure Drop to Atmosphere ( $\Delta p$ ) in psi		Cv															
		0.1	0.2	0.5	0.6	0.9	1.2	1.5	1.6	2.4	2.6	3.0	6.0	6.3	6.4	12.0	
Air SCFM @70°F(21°C)	10	1.1	2.7	6.9	8.3	12.0	17.0	21.0	22.0	33.0	36.0	41.5	83.0	87.2	88.6	166.0	
	50	3.0	7.6	19.1	23.0	34.0	46.0	57.0	61.0	92.0	99.5	115.0	230.0	241.0	245.0	459.0	
	100	5.3	14.0	33.9	40.7	61.0	81.0	100.0	110.0	160.0	176.0	203.0	407.0	427.0	434.0	814.0	
Water US GPM @70°F(21°C)	10	0.3	0.6	1.6	1.9	2.8	3.7	4.7	5.0	7.5	8.2	9.5	19.0	19.9	20.2	37.9	
	50	0.7	1.4	3.5	4.2	6.3	8.4	11.0	11.0	17.0	18.4	21.2	42.3	44.5	45.3	84.9	
	100	1.0	2.0	5.0	6.0	9.0	12.0	15.0	16.0	24.0	26.0	30.0	60.0	63.0	64.0	120.0	

The Cv is for the straight pattern valves, Cvs of angle pattern valves are the same as those of 3-way valves.

### 3-Way switching Valves

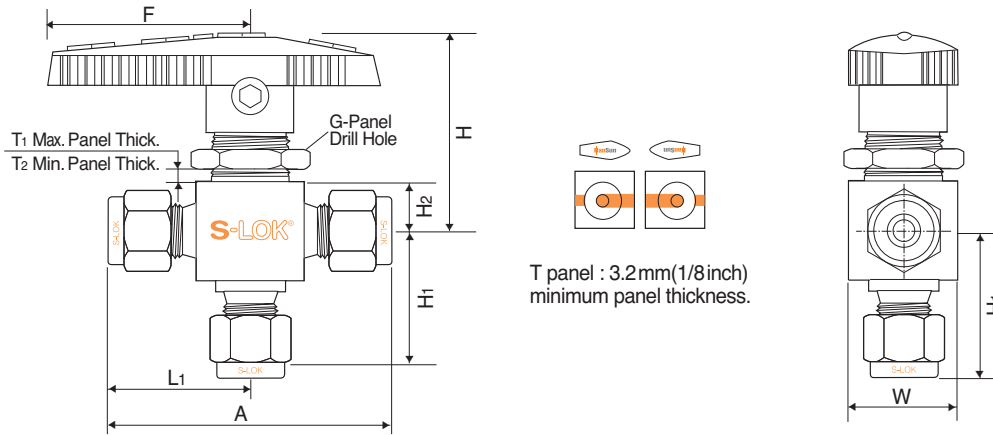

### Ordering Information and Dimensions

Basic Ordering Number	Orifice		Cv	End Connections	Dimensions (mm)										
	mm	inch			A	L <sub>1</sub>	H <sub>1</sub>	H <sub>2</sub>	F	T <sub>1</sub>	T <sub>2</sub>	G	H	W	
SBV1-3B	S-1T	1.3	0.052	0.08	1/16" S-LOK	42.7	21.3	20.6	8.6	28.7	6.4	2.0	15.1	34.5	14.7
	S-2T	2.4	0.093	0.15	1/8" S-LOK	51.1	25.6	24.6							
	S-4T	3.2	0.125	0.35	1/4" S-LOK	56.1	28.1	27.2							
	S-3M	2.4	0.093	0.15	3mm S-LOK	51.1	25.6	24.6							
	S-6M	3.2	0.125	0.35	6mm S-LOK	56.1	28.1	27.2							
	F-2N	3.2	0.125	0.3	1/8" Female NPT	41.1	20.6	20.6							
SBV2-3B	S-4T	4.8	0.187	0.90	1/4" S-LOK	60.7	30.4	29.7	11.2	38.9	4.8	2.5	19.8	39.6	19.8
	S-6M			0.90	6mm S-LOK	60.7	30.4	29.7							
	S-8M			0.90	8mm S-LOK	62.5	31.2	30.5							
	F-4N			0.75	1/4" Female NPT	52.3	26.2	26.2							
	F-4R			0.75	1/4" ISO Female Tapered	52.3	26.2	26.2							
SBV3-3B	S-6T	7.1	0.281	2.0	3/8" S-LOK	73.4	36.7	36.3	14.2	50.8	9.5	3.0	28.6	52.6	28.4
	S-10M			2.0	10mm S-LOK	73.4	36.7	36.3							
	F-4N			1.7	1/4" Female NPT	63.5	31.8	31.8							
	F-6N			1.5	3/8" Female NPT	63.5	31.8	31.8							
	F-6R			1.5	3/8" ISO Female Tapered	63.5	31.8	31.8							
SBV4-3B	S-8T	10.3	0.406	4.6	1/2" S-LOK	88.4	44.2	44.2	17.5	76.2	9.5	3.0	38.1	61.7	38.1
	S-12T	10.3	0.406	3.8	3/4" S-LOK	88.4	44.2	44.2							
	S-12M	9.5	0.375	4.6	12mm S-LOK	88.4	44.2	44.2							
	F-8N	10.3	0.406	3.5	1/2" Female NPT	79.5	39.8	39.6							
	F-8R	10.3	0.406	3.5	1/2" ISO Female Tapered	79.5	39.8	39.6							

All dimensions shown are for reference only and are subject to change. Dimensions with S-LOK nuts are in finger-tight position.

#### • Flow Rate

Pressure Drop to Atmosphere ( $\Delta p$ ) in psi	Cv													
	0.08	0.15	0.30	0.35	0.75	0.8	0.9	1.5	1.7	2.0	3.5	3.8	4.6	
Air SCFM @70°F(21°C)	10	0.9	2.0	4.2	4.8	10.0	11.0	12.0	20.8	23.5	27.7	48.4	52.6	63.7
	50	2.4	5.7	11.5	13.4	29.0	31.0	34.0	57.4	65.0	76.5	134.0	145.0	176.0
	100	4.3	10.1	20.3	23.7	51.0	54.0	61.0	102.0	115.0	136.0	237.0	258.0	312.0
Water US GPM @70°F(21°C)	10	0.3	0.4	0.9	1.1	2.3	2.5	2.8	4.7	5.4	6.3	11.1	12.0	14.5
	50	0.6	1.0	2.1	2.5	5.3	5.6	6.3	10.6	12.0	14.1	24.7	26.9	32.5
	100	0.8	1.5	3.0	3.5	7.5	8.0	9.0	15.0	17.0	20.0	35.0	38.0	46.0

## SBV2-4W/6W Series Ball Valves

### Features

- Crossover of two streams
- Machined stops provide positive port positioning.

### Technical Data

Ordering Number	Seat Material	Pressure Rating		Temperature Range
		psig	bar	
SBV2-4W-F-2N	PTFE	2500	172	10°C to 65°C (50°F to 150°F)
SBV2-4W-F-8N		1500	103	
SBV2-6W-S-1T/2T		500	34.4	
SBV2-4W-F-2N-PFA	PFA	2500	172	-54°C to 65°C (-65°F to 150 °F)
SBV2-4W-F-8N-PFA		1500	103	
SBV2-6W-1T-PFA/2T-PFA		500	34.4	

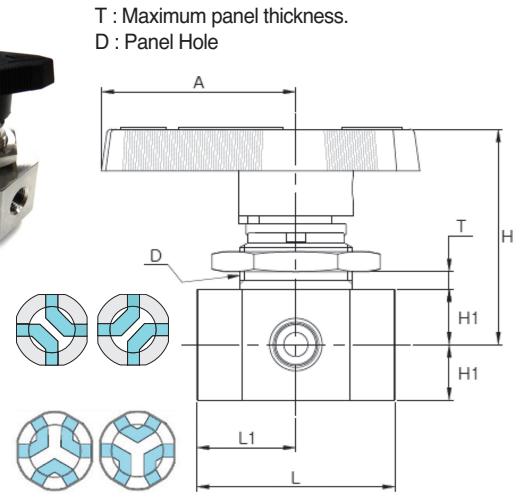

Ordering Number	End Connection	Cv	Orifice		Dimensions, mm(in.)							
			mm	in.	L	L1	H	H1	A	T	D	
SBV2-4W-F-2N	1/8 Female NPT	0.08	1.6	0.062	39.4 (1.55)	19.8 (0.78)	43 (1.69)	11.1 (0.44)	38.8 (1.53)	4.8 (0.19)	23.0 (0.91)	
SBV2-4W-F-8N	1/2 Female NPT	1.6	7.1	0.281	79.5 (3.13)	39.6 (1.56)	61.7 (2.43)	17.5 (0.69)	76.2 (3.0)	9.7 (0.38)	38.1 (1.5)	
SBV2-6W-S-1T	1/16 S-LOK Tube Fitting	0.06	1.3	0.052	49.3 (1.94)	24.6 (0.97)	42.7 (1.68)	11.2 (0.44)	38.9 (1.53)	4.8 (3/16)	23.1 (29/32)	
SBV2-6W-S-2T	1/8 S-LOK Tube Fitting	0.08	1.6	0.062								

## SBV2-5W/7W Series Ball Valves

### Features

- Flow can be switched from a single port to multiple ports or from multiple ports to a single port.
- 5way series valves have a spring-loaded detent for exact port positioning.

### Technical Data

Ordering Number	Seat Material	Pressure Rating		Temperature Range
		psig	bar	
SBV2-5W-F-2N	PTFE	2500	172	10°C to 65°C (50°F to 150°F)
SBV2-5W-F-2G		1500	103	
SBV2-5W-F-8N		500	34.3	
SBV2-7W-S-1T/2T	PFA	2500	172	-54°C to 65°C (-65°F to 150 °F)
SBV2-5W-F-2N-PFA		1500	103	
SBV2-5W-F-2G-PFA		1500	103	
SBV2-5W-F-8N-PFA		500	34.3	

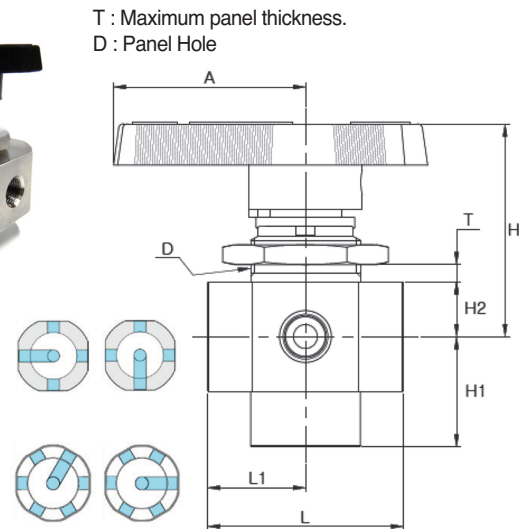

Ordering Number	End Connection	Cv	Orifice		Dimensions, mm(in.)							
			mm	in.	L	L1	H	H1	H2	A	T	D
SBV2-5W-F-2N	1/8 F.NPT	0.07	1.6	0.062	39.4 (1.55)	19.8 (0.78)	43 (1.69)	22.3 (0.88)	11.1 (0.44)	38.8 (1.53)	4.1 (0.16)	23.0 (0.91)
SBV2-5W-F-2G					1/8 F.PF	17.5 (0.69)	76.2 (3.0)	9.7 (0.38)	38.1 (1.5)			
SBV2-5W-F-8N	1/2 Female NPT	3.5	10.3	0.406	79.5 (3.13)	39.6 (1.56)	61.7 (2.43)	17.5 (0.69)	76.2 (3.0)	9.7 (0.38)	38.1 (1.5)	
SBV2-7W-S-1T	1/16 S-LOK Tube Fitting	0.05	1.3	0.052	49.3 (1.94)	24.6 (0.97)	42.9 (1.69)	24.6 (0.97)	11.2 (0.44)	38.9 (1.53)	4.1 (5/32)	23.1 (29/32)
SBV2-7W-S-2T	1/8 S-LOK Tube Fitting	0.07	1.6	0.062								

## Packing Adjustment

- SBV30 valves are designed to control fluid in full open and closed position ; using SBV30 valves to throttle the flow may reduce the valve life.
- Every valves are factory adjusted for 1000psig service at 70°F(21°C).
- For use in higher pressure, the packing must be readjusted.
- Exposure of valves to varying temperature can affect the initial packing load. You may need check leak and readjust packing bolt.
- Packing adjustment may be required during the valve in service.

## Testing

- Every valve is factory tested for bubble-tight leakage at both seat and stem packing with nitrogen at 1000psi (69bar).
- Seats have a maximum allowable leak rate of 0.1sccm. Optional tests are available upon request.

## • Ordering Information

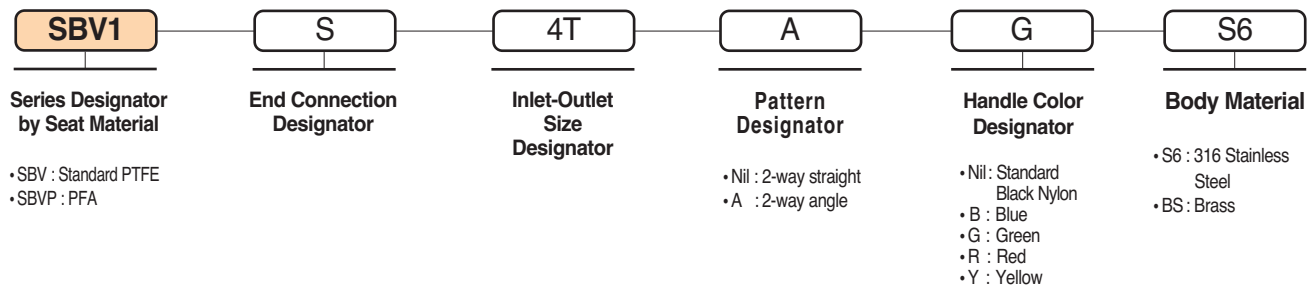

### **SAFETY in VALVE SELECTION**

When selecting a valve, the total system design must be considered to ensure safe, trouble-free performance. Valve function, materials compatibility, adequate ratings, proper installation, operation, and maintenance are the responsibility of the system designer and user.

## SBV60 Series High Pressure Ball Valves

### Features

- Pressure rating up to 10,000psig (689bar) @70°F (21°C).
- Temperature rating from -22°F (-30°C) to 265°F (130°C) with PVDF seat or from -65°F (-54°C) to 500°F (260°C) with PEEK seat.
- Robust body is best suited for high pressure application and allows various pattern including : 2-way straight pattern, 3-way side port inlet, 3-way bottom port inlet.
- Panel mounting and locking devices are available as options.
- Blow out proof design with internally loaded stem.
- Floating ball design ensures leak proof shut-off at high pressure.
- Straight through flow path for minimum pressure drop.
- Variety of end connections include reliable S-LOK tube fittings, male/female NPT & ISO/BSP threads.
- Handle with PVC Color coated allows easy and quick operation with low torque.
- 90 degree actuation.
- Every valve is 100% factory tested with the nitrogen @1000psi (69bar).
- Optional sour gas service to NACE MR 0175.



### Operation

- HANSUN SBV60 Series ball valves provide quick 1/4 turn on-off control of fluids in process, power and instrumentation applications.
- All ports are suitable as inlets in full operation pressure of the valve.
- A broad selection of valve body, seat, and seal materials provide a wide range of pressure and temperatures at which the valve may be used.
- Valves that have not been actuated for a period of time may have a higher actuation torque.

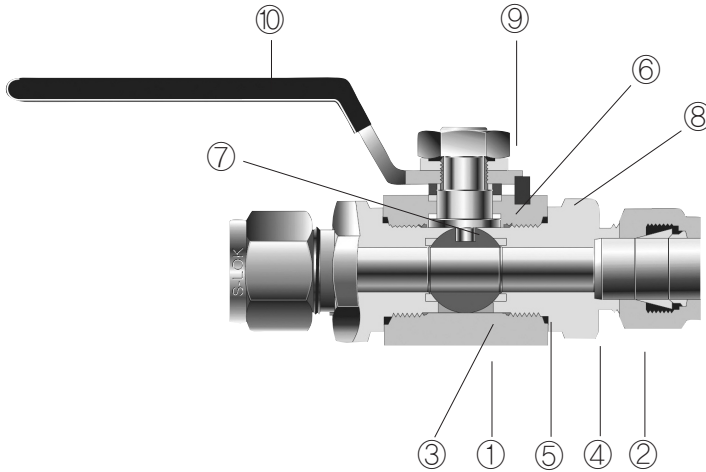

### Materials of Construction

Item	Description	Grade/ASTM Specification
1	Body	S316/A276, A479
2	End Connector	S316/A276, A479
3	Ball	S316/A276, A479
4	End Seals	Fluorocarbon FKM O-ring
5	Seats	PCTFE, optional PEEK
6	Stem	S316/A276, A479
7	Stem Packing	PTFE/D1710
8	Pin	Stainless Steel
9	Lock Nut	Stainless Steel with Washer
10	Handle	S304 with PVC Coating

※ Note : wetted parts are listed in orange color.  
Lubricant is Fluorocarbon based.

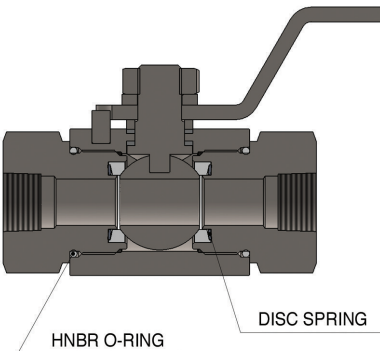

### CNG / NGV Certifications

- End Seal : HNBR O-ring
- Added Disc Spring
- Seat : PEEK

Valve Series	Certificates	ECE R110	ANSI NGV 3.1 - 2012	ISO 15500
SBVC Series	Certificate No.	110R-010333	126840AUT14	126840MECH103
	Classification	Class 0	Manual valve	Manual valve
	Temperature	-40 to 120°C (-40 to 248°F)	-40 to 120°C (-40 to 248°F)	-40 to 120°C (-40 to 248°F)
	Working Pressure	260 bar @ 120°C	248 bar @ 120°C	260 bar @ 120°C

2-Way

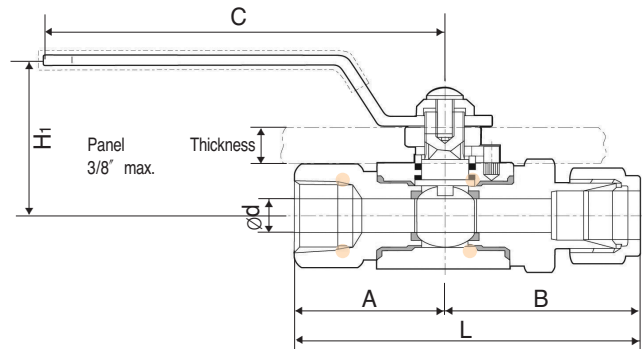
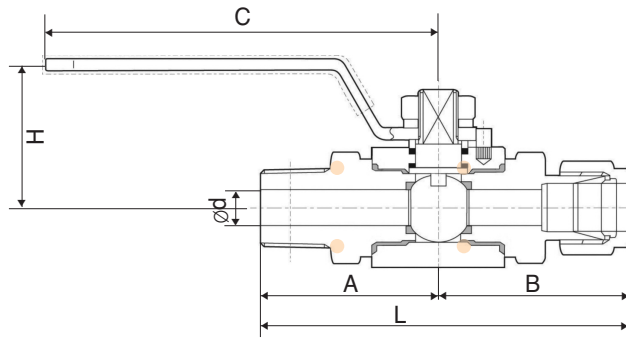

SBV60 2-way  
Pressure-Temperature  
Curves for valves with  
PEEK seat

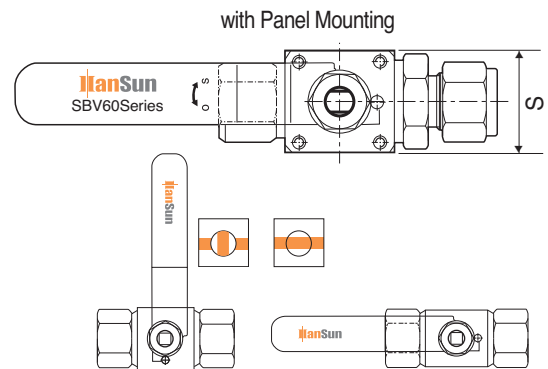
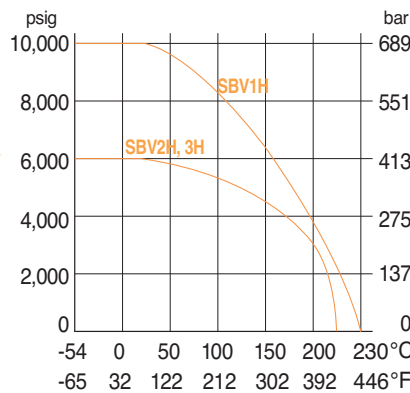

Ordering Information and Dimensions

Basic Ordering Number	Orifice mm (inch)	Cv	End Connections	d mm	Dimensions (mm)							
					A	B	L	H	H <sub>1</sub>	C	S	
SBV1H	S-4T	1.2	1/4" S-LOK	4.8	46	46	92	39	46.7	101	32	
	S-6T		3/8" S-LOK	7.1	47.5	47.5	95					
	S-8T	7.5	1/2" S-LOK	10.0	50	50	100					
	F-4N		1/4" Female NPT		32.5	32.5	65					
	F-6N		3/8" Female NPT		36	36	72					
	F-8N	1/2" Female NPT	43	43	86							
	M-4N	3.7	1/4" Male NPT	7.1	42	42	84					
	M-6N		3/8" Male NPT	9.7	42	42	84					
	M-8N		1/2" Male NPT	10.0	47.5	47.5	95					
SBV2H	12.7(0.50)	10.1	1/2" Female NPT	12.7	45.5	45.5	91	51	60.6	135	40	
			3/4" Female NPT		47.5	47.5	95					
			3/4" Male NPT		54.5	54.5	109					
			5/8" S-LOK		55.5	55.5	111					
			3/4" S-LOK		55.5	55.5	111					
SBV3H	19.0(0.75)	30.0	3/4" Female NPT	20.0	48	48	96	56	65.6	135	50	
			1" Female NPT		50	50	100					
		S-12T	19.0	3/4" S-LOK	15.8	58.5	58.5					117
		S-16T	30.0	1" S-LOK	20.0	65	65					130
		M-12N	19.0	3/4" Male NPT	15.8	58	58					116
		M-16N	30.0	1" Male NPT	20.0	62.5	62.5					125

All dimensions shown are for reference only and are subject to change. Dimensions with S-LOK nuts are in finger-tight position.

3-Way

**SIDE PORT INLET**

1/4 turn handle  
For flow switching

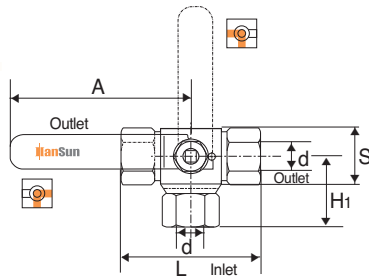

**BOTTOM PORT INLET**

1/2 turn handle  
For flow switching and isolation

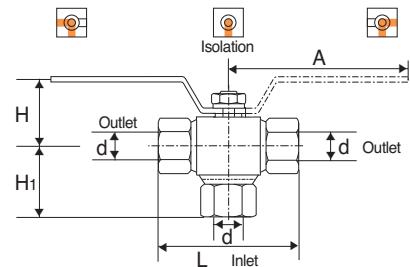

Ordering Information and Dimensions

Basic Ordering Number	End Connections Inlet & Outlet	Orifice mm (inch)	d mm	Dimensions mm				
				A	H	H1	L	S
SBV1H-3*	S-4T 1/4" S-LOK	10.0(0.39)	4.8	101	39	51.5	92	32
	S-6T 3/8" S-LOK		7.1			53.0	95	
	S-8T 1/2" S-LOK		10.0			55.8	100	
	F-4N 1/4" Female NPT		36.7			65		
	F-6N 3/8" Female NPT		40.2			72		
	F-8N 1/2" Female NPT		45.5			86		
SBV2H-3*	F-8N 1/2" Female NPT	12.7(0.50)	12.7	135	51	49.7	91	40
	F-12N 3/4" Female NPT					55.2	95	
	S-10T 5/8" S-LOK					65.5	111	
	S-12T 3/4" S-LOK					65.5	111	
SBV3H-3*	S-12T 3/4" S-LOK	19.0(0.75)	15.8	135	56	70.0	117	50
	S-16T 1" S-LOK		20.0			76.6	130	
	F-12N 3/4" Female NPT		56.7			116		
	F-16N 1" Female NPT		60.8			125		

All dimensions shown are for reference only and are subject to change. Dimensions with S-LOK nuts are in finger-tight position.  
Ordering information : \* "S" for side entry 3-way ordering i.e., SBV1H-3S-S-8T, \* "B" for bottom entry 3-way ordering i.e., SBV1H-3B-S-8T

Handle Turn torque Table (N·m)

Valve Series	Applied Working Pressures – psig(bar)						
	0(0)	69(1000)	137(2000)	206(3000)	275(4000)	344(5000)	413(6000)
SBV1H	0.30(0.22)	0.35(0.25)	0.40(0.29)	0.40(0.29)	0.40(0.29)	0.40(0.29)	0.45(0.33)
SBV2H	1.20(0.88)	1.50(1.10)	1.70(1.25)	1.70(1.25)	1.80(1.32)	1.90(1.40)	2.00(1.47)
SBV3H	1.70(1.25)	1.80(1.32)	1.90(1.40)	2.00(1.47)	2.10(1.55)	2.20(1.62)	2.30(1.69)

Technical Data-Pressure and Temperature Rating

2-way

Valve Series	Sealing Materials			Pressure Rating @ -54°C to 21°C (-65°F to 70°F)	Temperature Rating
	Seat	Stem Packing	End Seal		
SBV1H	PCTFE	PTFE	FKM	6,000psig (413bar)	-30°C to 180°C (-22°F to 355°F)
	PEEK			10,000psig (689bar)	-54°C to 230°C (-65°F to 446°F)
SBV2H	PCTFE	PTFE	FKM	5,000psig (344bar)	-23°C to 160°C (-9°F to 320°F)
SBV3H	PEEK			6,000psig (413bar)	-35°C to 210°C (-31°F to 410°F)

3-way

Valve Series	Sealing Materials			Pressure Rating @ -54°C to 21°C (-65°F to 70°F)	Temperature Rating
	Seat	Stem Packing	End Seal		
SBV1H	PCTFE	PTFE	FKM	4,000psig (275bar)	-30°C to 180°C (-22°F to 355°F)
	PEEK			6,000psig (413bar)	-54°C to 230°C (-65°F to 446°F)
SBV2H	PCTFE	PTFE	FKM	3,000psig (206bar)	-23°C to 160°C (-9°F to 320°F)
SBV3H	PEEK			4,000psig (275bar)	-35°C to 210°C (-31°F to 410°F)

- \* The above pressure rating is for 2-way In-line pattern valves. 80% of the above rating shall be applicable to 2-way angle pattern valves and 3-way valves.
- \* The rated pressure shown above is the maximum allowable pressure to the seat. If the system requires higher pressure to test, the valve must be in open position before and during test so as not to damage the seat.
- \* Pressure ratings of valves are sometimes limited to the maximum working pressure of pipe ends and tubing connected. The working pressure of tubing must be considered in the calculation of total system working pressure.

## Panel Mounting

### Locking nut panel mounting

Ordering designator : PN

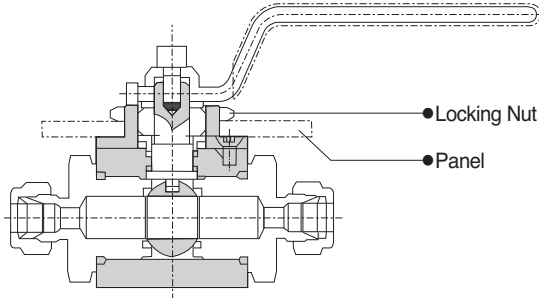

### Screw hole panel mounting

Ordering designator : PS

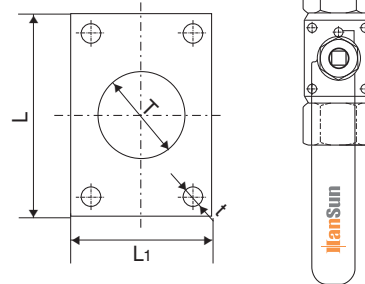

### • PN-Panel Mount Information Unit:mm(inch)

Valve Series	Panel Hole Drill	Panel Thickness
SBV1H	30.0(1.18)	Max. 4.0(0.157)
SBV2H	38.0(1.50)	Max. 4.0(0.157)
SBV3H	38.0(1.50)	Max. 4.0(0.157)

### • PS-Panel Mount Information Unit:mm(inch)

Valve Series	L	L1	t	T
SBV1H	34.0(1.33)	23.0(0.91)	4.0(0.15)	30.0(1.18)
SBV2H	36.0(1.42)	29.0(1.14)	5.0(0.20)	38.0(1.50)
SBV3H	40.0(1.57)	35.0(1.37)	6.0(0.23)	38.0(1.50)

### • Sour Gas Service

Is provided to meet NACE Standard MR 0175.

### Testing

- Every valve is factory tested for bubble-tight leakage at both seat and stem packing with nitrogen at 1000psi (69bar).
  - Hydraulic shell test is performed at 1.5 times the working pressure.
  - Seats have a maximum allowable leak rate of 0.1 sccm.
- optional tests are available upon request.

### • Ordering Information

Selection the applicable options from designators listed below.

SBV1H	S	4T	PK	PN	LD	OH	SG	S6
Series Designator by Orifice Size	End Connection Designator	Inlet-Outlet Size Designator	Seat Material Designator	Panel Mounting	Locking Device	Handle	Sour Gas Designator	Body Material
			• Nil : Standard PCTFE • PK : PEEK	• PN : Lock nut panel mounting • PS : Screw hole panel mounting	• LD : Locking Device	• Nil : Standard lever handle • OH: Oval Handle (Applicable only for SBV1H)	• Nil : Without(Standard) • SG: Sour Gas Service	• S6 : 316 Stainless Steel

### ※ CNG / NGV Service

- To order CNG / NGV Service, insert the designator "C" to the valve ordering number.
  - Material's PEEK standard.
- ex) SBVC1H-S-4T-S6

### SAFETY in VALVE SELECTION

When selecting a valve, the total system design must be considered to ensure safe, trouble-free performance. Valve function, materials compatibility, adequate ratings, proper installation, operation, and maintenance are the responsibility of the system designer and user.

## SFBV60 Series Forged High pressure Ball Valves

### Features

- Pressure rating up to 6,000psig (413bar) @70°F (21°C).
- Temperature rating from -65°F (-54°C) to 350°F (177°C) with Standard PCTFE seat.
- Free floating ball design provides seat wear compensation, therefore ensures leak proof shut-off at high pressure.
- High flow in a compact design.
- Panel mountable as standard.
- Blow out proof design with internally loaded stem.
- Micro-finished ball provides a positive seal.
- Low operating torques and positive handle stops.
- Handle indicates flow direction.
- Straight through flow path for minimum pressure drop.
- Bi-Directional flow.
- Chevron packing standard for positive leak tight.
- 90 degree actuation.
- Every valve is 100% factory tested with the nitrogen @1000psi (69bar).
- Variety of end connections include reliable S-LOK tube fittings, Male/Female NPT & ISO/BSP threads.



### Applications

- Water
- Oil
- Gas
- Petrochemical

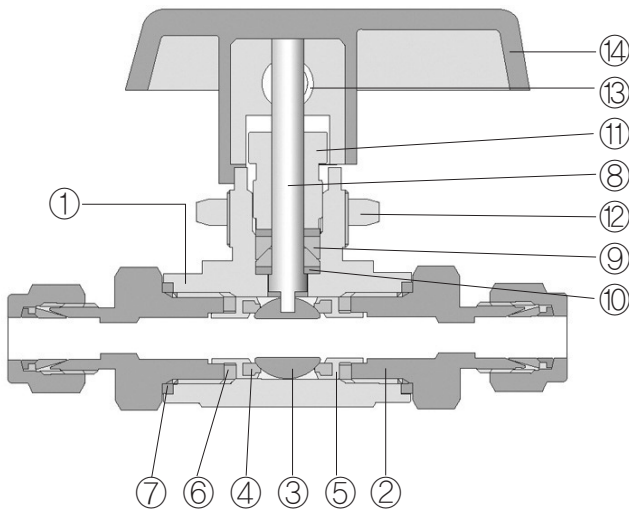

### CNG / NGV Certifications

- CNG / NGV Valves added HNBR o-ring and added disc spring.
- Seat Material's PEEK standard

Valve Series	Certificates	ECE R110	ANSI NGV 3.1 - 2012	ISO 15500
SFBVC Series	Certificate No.	110R-010333	126840AUT14	126840MECH103
	Classification	Class 0	Manual valve	Manual valve
	Temperature	-40 to 120°C (-40 to 248°F)	-40 to 120°C (-40 to 248°F)	-40 to 120°C (-40 to 248°F)
	Working Pressure	260 bar @ 120°C	248 bar @ 120°C	260 bar @ 120°C

### Testing

- Every valve is factory tested for bubble-tight leakage at both seat and stem packing with nitrogen at 1000psi (69bar).
- Seats have a maximum allowable leak rate of 0.1 sccm.
- Optional tests are available upon request.

### Materials of Construction

Item	Description	Grade / ASTM Specification
1	Body	S316/A276, A479
2	End Connector	S316/A276, A479
3	Ball	S316/A276, A479
4	Seats	PCTFE, optional PTFE, PEEK
5	Retainer	S316/A276, A479
6	Retainer Seal	PTFE
7	End Seals	PTFE
8	Stem	S316/A276, A479
9	Stem Packing	PTFE
10	Stem Washer	S316
11	Packing Bolt ①	S316/A276, A479
12	Lock Nut	S316/A276, A479
13	Set Screw	Stainless Steel
14	Handle	Black Nylon standard

① Molybdenum disulfide with hydrocarbon coating.

※ Note : wetted parts are listed in orange color.  
Lubricant is Fluorocarbon based.

### 2-Way (Shut-Off Valve)

In-line pattern

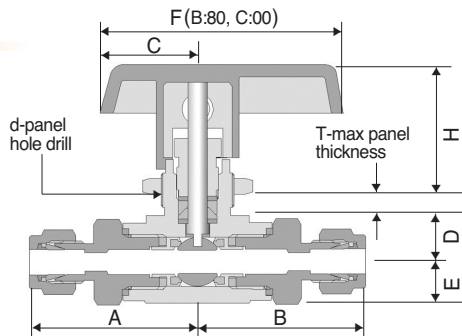
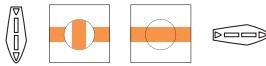

### Ordering Information and Dimensions

Basic Ordering Number	End Connections		Orifice mm (in.)	Cv	Dimensions mm (inch)														
	Inlet	Outlet			A	B	D	E	H	C	F	d	T						
SFBV1	S-1T	1/16" S-LOK	1.3(0.052)	0.06	33.0(1.30)	33.0(1.30)	9.4 (0.37)	10.0 (0.39)	23.2 (0.91)	19 (0.75)	47.0 (1.85)	16.3 (0.64)	3.3 (0.13)						
	S-2T	1/8" S-LOK	2.4(0.093)	0.21	34.5(1.36)	34.5(1.36)													
	F-2N	1/8" Female NPT	4.2(0.165)	0.93	27.2(1.07)	27.2(1.07)													
	M-2N	1/8" Male NPT			29.9(1.18)	29.9(1.18)													
	S-4T	1/4" S-LOK			37.6(1.48)	37.6(1.48)													
	M-4N	1/4" Male			34.3(1.35)	34.3(1.35)													
S-3M	3mm S-LOK	2.2(0.086)	0.18	34.8(1.37)	34.8(1.37)	11.9 (0.47)	10.7 (0.42)	38.9 (1.53)	25.6 (1.01)	78 (3.07)	19.6 (0.77)	6.4 (0.25)							
S-2T	1/8" S-LOK	2.4(0.093)	0.26	41.9(1.65)	41.9(1.65)														
S-4T	1/4" S-LOK	4.8(0.189)	1.04	44.2(1.74)	41.1(1.62)														
MS-4N4T	1/4" Male NPT   1/4" S-LOK			44.2(1.74)	41.1(1.62)														
FS-4N6T	1/4" Female NPT   1/4" S-LOK	6.4(0.250)	2.34	38.4(1.51)	38.4(1.51)														
F-4N	1/4" Female NPT			38.4(1.51)	38.4(1.51)														
M-4N	1/4" Male NPT			41.1(1.62)	41.1(1.62)														
MF-4N	1/4" Male NPT   1/4" Female NPT			38.4(1.51)	41.1(1.62)														
MS-4N6T	1/4" Male NPT   3/8" S-LOK			45.7(1.80)	38.4(1.51)														
FS-4F6T	1/4" Female NPT   3/8" S-LOK			45.7(1.80)	38.4(1.51)														
S-6T	3/8" S-LOK	6.4(0.250)	2.34	41.1(1.62)	41.1(1.62)								17.8 (0.70)	17.5 (0.69)	44.2 (1.74)	38.1 (1.50)	99 (3.9)	22.9 (0.90)	9.7 (0.38)
M-6N	3/8" Male NPT			41.1(1.62)	41.1(1.62)														
S-6M	6mm S-LOK			4.8(0.189)	1.04	44.5(1.75)	44.5(1.75)												
S-8M	8mm S-LOK			9.5(0.375)	5.57	45.2(1.78)	45.2(1.78)												
S-10M	10mm S-LOK					46.0(1.81)	46.0(1.81)												
F-6N	3/8" Female NPT			10.3(0.406)	6.42	49.5(1.95)	49.5(1.95)												
F-8N	1/2" Female NPT	54.6(2.15)	54.6(2.15)																
S-8T	1/2" S-LOK	59.4(2.34)	59.4(2.34)																
M-8N	1/2" Male NPT	56.4(2.22)	56.4(2.22)																
S-12T	3/4" S-LOK	9.5(0.375)	5.57			59.2(2.33)	59.2(2.33)												
S-12M	12mm S-LOK					59.2(2.33)	59.2(2.33)												
S-16M	16mm S-LOK	10.3(0.406)	6.42																

Dimensions are for reference only and are subject to change. Dimensions with S-LOK nuts are in finger-tight position.

#### • Flow Rate

Pressure Drop to Atmosphere ( $\Delta p$ ) in psi	Cv									
	0.06	0.18	0.21	0.26	0.93	1.04	2.34	5.57	6.42	
Air SCFM @70°F (21°C)	10	5.9	17.7	20.7	25.6	91.5	102.4	230.3	548.2	631.9
	50	13.2	39.6	46.2	57.2	204.7	228.9	515.0	1225.9	1413.0
	100	18.7	56.0	65.4	80.9	289.5	323.7	728.3	1733.7	1998.3
Water US GPM @60°F (16°C)	10	0.2	0.6	0.7	0.8	2.9	3.3	7.4	17.6	20.3
	50	0.4	1.3	1.5	1.8	6.6	7.4	16.5	39.4	45.4
	100	0.6	1.8	2.1	2.6	9.3	10.4	23.4	55.7	64.2

\* Flow rate calculated with 1000psig (69bar) inlet pressure.

\* To determine m<sup>3</sup>/hr multiply GPM by 0.227 and SCFM by 1.69

### 3-Way (Switching Valve)

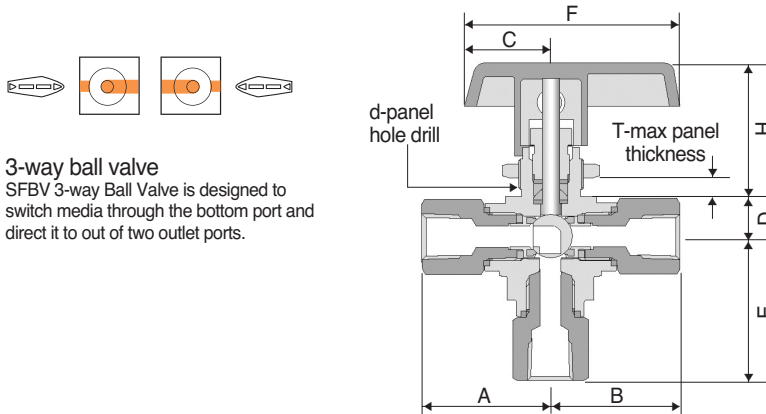

**3-way ball valve**  
 SFBV 3-way Ball Valve is designed to switch media through the bottom port and direct it to out of two outlet ports.

### Ordering Information and Dimensions

Basic Ordering Number	End Connections		Orifice mm(in.)	Cv	Dimensions mm(inch)							
	Inlet	Outlet			A	B	E	D	H	C	F	d
SFBV1-3B	S-1T	1/16" S-LOK	1.3(0.052)	0.06	33.0(1.30)	33.7(1.30)	8.5 (0.33)	23.2 (0.91)	18.0 (0.71)	47.0 (1.85)	16.3 (0.64)	3.3 (0.13)
	S-2T	1/8" S-LOK	2.4(0.093)	0.21	34.5(1.36)	36.4(1.36)						
	F-2N	1/8" Female NPT	4.2(0.165)	0.63	27.2(1.07)	29.9(1.18)						
	M-2N	1/8" Male NPT			29.9(1.18)	29.9(1.18)						
	S-4T	1/4" S-LOK			37.6(1.48)	37.2(1.46)						
	M-4N	1/4" Male			34.3(1.35)	29.9(1.18)						
S-3M	3mm S-LOK	2.2(0.086)	0.18	34.8(1.37)	36.4(1.36)							
SFBV2-3B	S-2T	1/8" S-LOK	2.4(0.093)	0.21	41.9(1.65)	45.5(1.79)	11.9 (0.47)	38.9 (1.53)	30 (1.18)	78 (3.07)	19.6 (0.77)	6.4 (0.25)
	S-4T	1/4" S-LOK	4.8(0.189)	0.70	44.2(1.74)	47.8(1.88)						
	F-4N	1/4" Female NPT	5.0(0.196)	0.87	38.4(1.51)	41.9(1.65)						
	M-4N	1/4" Male NPT	5.0(0.196)	0.87	41.1(1.62)	44.7(1.76)						
	S-6T	3/8" S-LOK			45.7(1.80)	49.3(1.94)						
	M-6N	3/8" Male NPT	41.1(1.62)	44.7(1.76)								
	S-6M	6mm S-LOK	4.8(0.189)	0.70	44.5(1.75)	47.8(1.88)						
	S-8M	8mm S-LOK	5.0(0.196)	0.87	45.2(1.78)	48.5(1.91)						
S-10M	10mm S-LOK	46.0(1.81)			49.5(1.95)							
SFBV3-3B	F-6N	3/8" Female NPT	10.3(0.406)	3.62	49.5(1.95)	58.2(2.29)	17.8 (0.70)	44.2 (1.74)	38.1 (1.50)	99 (3.9)	22.9 (0.90)	9.7 (0.38)
	F-8N	1/2" Female NPT			54.6(2.15)	63.2(2.49)						
	S-8T	1/2" S-LOK			59.4(2.34)	68.1(2.68)						
	M-8N	1/2" Male NPT			56.4(2.22)	65.8(2.59)						
	S-12T	3/4" S-LOK			59.2(2.33)	68.1(2.68)						
	S-12M	12mm S-LOK				67.8(2.67)						
	S-16M	16mm S-LOK			10.3(0.406)	3.62						

Dimensions are for reference only and are subject to change. Dimensions with S-LOK nuts are in finger-tight position.

#### • Flow Rate

Pressure Drop to Atmosphere ( $\Delta p$ ) in psi	Cv											
	0.06	0.18	0.21	0.63	0.7	0.87	0.93	2.34	3.46	3.62	6.42	
Air SCFM @ 70°F (21°C)	10	5.9	17.7	20.7	62.0	68.9	85.6	91.5	230.3	340.6	356.3	631.9
	50	13.2	39.6	46.2	138.7	154.1	191.5	204.7	515.0	761.5	796.7	1413.0
	100	18.7	56.0	65.4	196.1	217.9	270.8	289.5	728.3	1077.0	1126.8	1998.3
Water US GPM @ 60°F (16°C)	10	0.2	0.6	0.7	2.0	2.2	2.8	2.9	7.4	10.9	11.4	20.3
	50	0.4	1.3	1.5	4.5	4.9	6.2	6.6	16.5	24.5	25.6	45.4
	100	0.6	1.8	2.1	6.3	7.0	8.7	9.3	23.4	34.6	36.2	64.2

\* Flow rate calculated with 1000psig (69bar) inlet pressure.

\* To determine m<sup>3</sup>/hr multiply GPM by 0.227 and SCFM by 1.69

## Technical Data-Pressure and Temperature Rating

Seat Materials	Pressure Rating @ 100°F (70°C)	Temperature Rating	Pressure Rating @ Max Temperature
PCTFE	6,000psig (413bar)	-54°C to 177°C (-65°F to 350°F)	1,000psig @ 350°F (69bar @ 177°C)
PEEK	6,000psig (413bar)	-54°C to 232°C (-65°F to 450°F)	700psig @ 450°F (48bar @ 232°C)
PTFE	1,500psig (103bar)	-54°C to 177°C (-65°F to 350°F)	250psig @ 350°F (17.2bar @ 177°C)

**Caution** Pressure Rating with 3-way side ports of as inlet : 150psig (10bar)

## Ordering Information

Selection the applicable options from designators listed below.

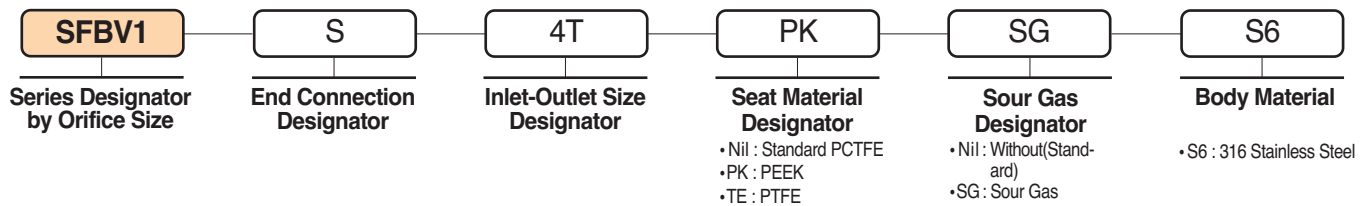

### ※ CNG / NGV Service

- To order CNG / NGV Service, insert the designator "C" to the valve ordering number.
  - Seat Material's PEEK standard.
- ex) SFBV**C**1 – S – 4T – S6

### **SAFETY in VALVE SELECTION**

When selecting a valve, the total system design must be considered to ensure safe, trouble-free performance. Valve function, materials compatibility, adequate ratings, proper installation, operation, and maintenance are the responsibility of the system designer and user.

## ■ STBV60 Series up to 6000 psi

## ■ STBVC Series CNG/NGV Valves up to 3770 psi

### Features

- Working pressure up to 6,000psi(413bar)@100°F(38°C).
- Compact, maximum flow design.
- Panel mountable as standard.
- Handle indicates flow direction.
- Low torque actuation.
- 2-way "Shut-up" and 3-way "Switching" type.
- Various end connections : include S-LOK Tube Fittings, NPT / ISO male & female.
- Optional sour gas service to NACE MR 0175.
- Every valve is 100% factory tested.



### Technical Data

Valve Series	Seat Material	Temperature Rating °C (°F)	Pressure Rating @38 °C (100°F)
STBV60	PCTFE	-17 to 121 (0 to 250)	6,000psig (413bar)
	PEEK	-17 to 232 (0 to 450)	6,000psig (413bar)
	PTFE		1,500psig (103bar)

### Testing

- The rated pressure shown above is the maximum allowable pressure to the seat. If the system requires higher pressure to test, the valve must be in open position before and during test so as not to damage the seat.
- Every valve is factory tested for bubble - tight leakage at both seat and stem packing with nitrogen at 1000psi(69bar).
- Hydraulic shell test is performed at 1.5times the working pressure.
- Seats have a maximum allowable leak rate of 0.1 SCCM.
- Optional tests are available upon request.

### CNG / NGV Information

- STBVC Series valve provides leak - tight integrity in both low and high pressure systems in CNG and NGV applications. Valves with peek seat and HNBR O-ring are compatible with CNG fluid.

Valve Series	Certificates	ECE R110	ANSI NGV 3.1-2012	ISO 15500
STBVC Series 2-Way	Certificate No.	110R-010333	126840AUT14	126840MECH103
	Classification	Class 0	Manual valve	Manual valve
	Temperature	-40 to 120°C (-40 to 248°F)	-40 to 120°C (-40 to 248°F)	-40 to 120°C (-40 to 248°F)
	Working Pressure	260 bar @ 120 °C	248 bar @ 120 °C	260 bar @ 120 °C
STBVC Series 3-Way	Certificate No.	110R-000184	110R-000184	110R-000184
	Classification	Class 0	Manual valve	Manual valve
	Temperature	-40 to -120°C (-40 to 248°F)	-40 to -120°C (-40 to 248°F)	-40 to -120°C (-40 to 248°F)
	Working Pressure	260 bar @ 38 °C	260 bar @ 38 °C	260 bar @ 38 °C

## Materials of Construction

### STBV60 & STBVC 2-Way

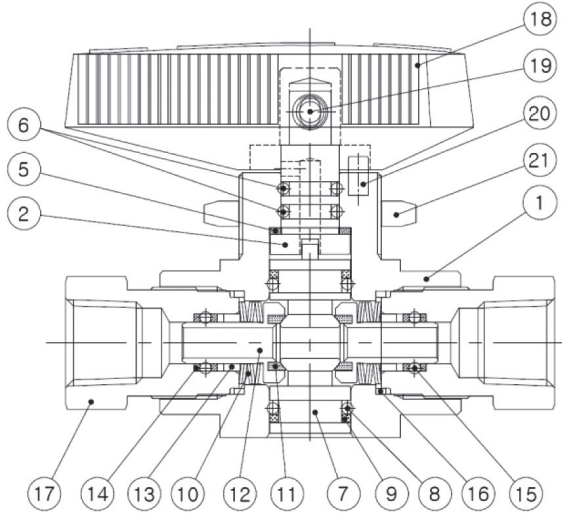

### STBV60 & STBVC 3-Way

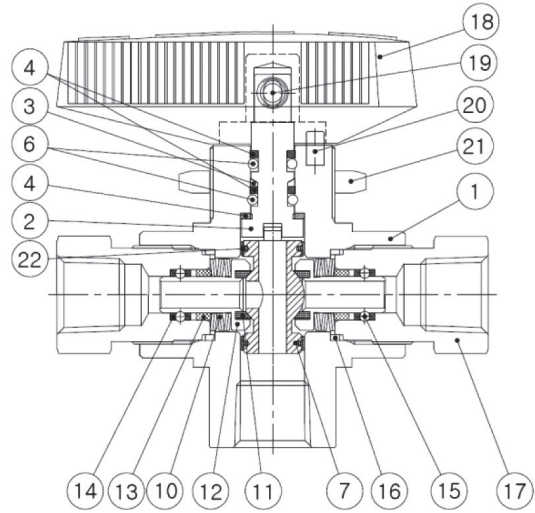

Item	Description	STBV60 Series		STBVC Series	
		2-Way	3-Way	2-Way	3-Way
Grade/ASTM Specification					
1	Body	S316 / A276 or A479			
2	Stem*	S316 / A276 or A479			
3	Stem Support Ring*	-	PEEK	-	PEEK
4	Stem Backup Ring*	-	PTFE	-	PTFE
5	Stem Bearing*	PEEK			
6	Stem O-Ring*	FKM		HNBR	
7	Trunnion Ball*	S316 / A276 or A479			
8	Ball O-Ring*	FKM	-	HNBR	-
9	Ball Backup Ring*	PTFE	-	PTFE	-
10	Disc Spring*	Alloy X-750 / AMS 5542			
11	Seat*	PCTFE, optional PTFE, PEEK		PEEK	
12	Seat Carrier*	S316 / A276 or A479			
13	Seat Carrier Guide*	S316 / A276 or A479			
14	Seat Carrier Backup Ring*	PTFE			
15	Seat Carrier O-Ring*	FKM		HNBR	
16	End Connector Packing*	PTFE / D1710, Type 1			
17	End Connector	S316 / A276 or A479			
18	Handle*	Phenolic with brass insert			
19	Set Screw*	S316			
20	Stop Pin	S316			
21	Lock Nut	S316 / A276 or A479			
22	Slip Ring*	-	PTFE	-	PTFE

\* Service kits contain part

## Table of Dimensions

### STBV60 & STBVC 2-Way

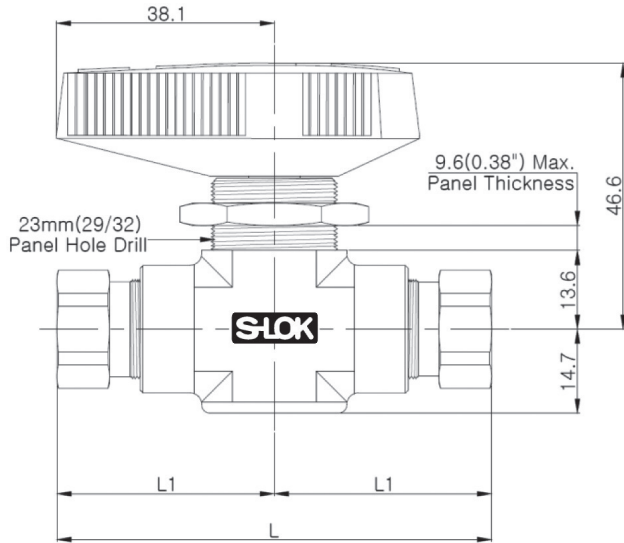

### STBV60 & STBVC 3-Way

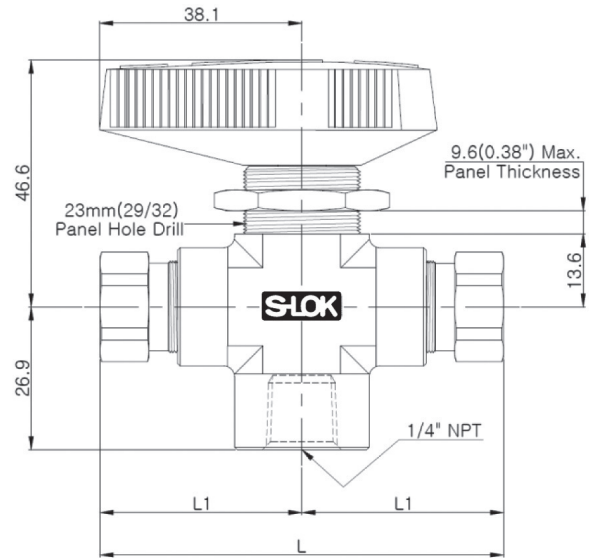

2-Way Valve Orifice 4.75mm (0.187 in.)					
STBV60 Series Ordering Numbers	End Connection		Cv	Dimensions mm(in.)	
	Inlet	Outlet		L	L1
STBV / STBVC	F-2N	1/8" Female NPT	1.2	76.2 (3)	38.1 (1.5)
	F-4N	1/4" Female NPT	1	76.2 (3)	38.1 (1.5)
	-	1/4" Female NPT	1	99.8 (3.93)	50 (1.97)
	F-8N	1/2" Female NPT	1.2	108 (4.25)	54.1 (2.13)
	S-4T	1/4" S-LOK	1.6	105 (4.14)	52.6 (2.07)
	S-6T	3/8" S-LOK	1.4	112 (4.41)	55.6 (2.19)
	S-8T	1/2" S-LOK	1	117 (4.6)	58.4 (2.3)
	S-6M	6mm S-LOK	1.6	105 (4.14)	52.6 (2.07)
	S-8M	8mm S-LOK	1.5	105 (4.14)	52.6 (2.07)
	S-10M	10mm S-LOK	1.3	112 (4.41)	55.9 (2.2)
S-12M	12mm S-LOK	1	117 (4.6)	58.4 (2.3)	
3-Way Valve Orifice 4.75mm (0.187 in.)					
STBV-3B / STBVC-3B	F-2N	1/8" Female NPT	0.75	76.2 (3)	38.1 (1.5)
	F-4N	1/4" Female NPT		76.2 (3)	38.1 (1.5)
	-	1/4" Female NPT		99.8 (3.93)	50 (1.97)
	S-4T	1/4" S-LOK		105 (4.14)	52.6 (2.07)
	S-6T	3/8" S-LOK		112 (4.41)	55.6 (2.19)
	S-8T	1/2" S-LOK		117 (4.6)	58.4 (2.3)
	S-6M	6mm S-LOK		105 (4.14)	52.6 (2.07)
	S-8M	8mm S-LOK		105 (4.14)	52.6 (2.07)
	S-10M	10mm S-LOK		112 (4.41)	55.9 (2.2)
	S-12M	12mm S-LOK		117 (4.6)	58.4 (2.3)

## Ordering Information

- Selection of the applicable options from the designators are listed below.

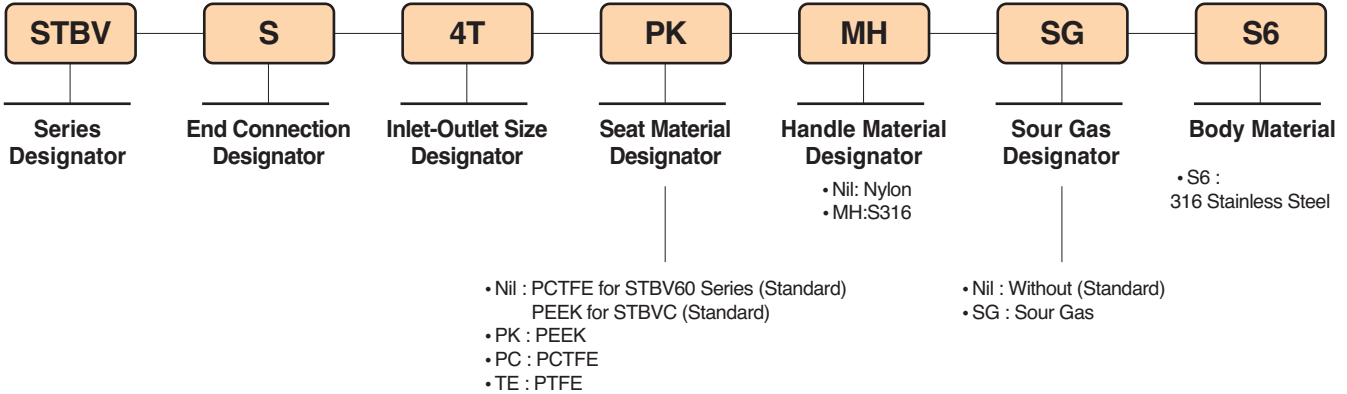

## Safety in Valve Selection

- When selecting a valve, the total system design must be considered to ensure safe, trouble - free performance.
- Valve function, materials compatibility, adequate ratings, proper installation, operation, and maintenance are the responsibility of the system designer and user.

## Service Kit

Service kits contain components of the same materials as new components.

To order the service kit, selection of the applicable options from the designators are listed mark(\*) of 19page.

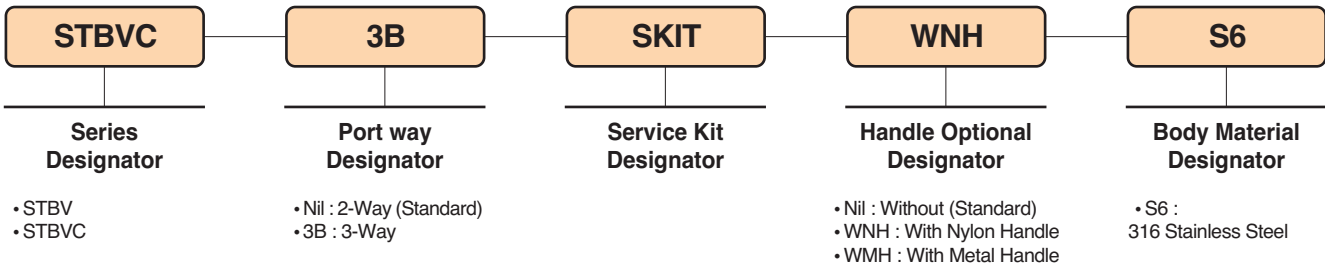

## SDBV Series Ball Valves for DIN Standard

### Features

- Pressure rating up to 500barg @ 21°C
- Temperature rating from -20°C to 100°C with POM and FKM(Viton) standard.
- Conforms to DIN standard.
- Compact design with maximum orifice.
- Variety of end connections such as DIN 2353 “L” & “S” series, Male & Female DIN / ISO/ BSP and NPT threads.
- Handle is only available in cast stainless steel standard.
- Every valve is 100% factory tested with the Nitrogen @1,000psig (68barg)

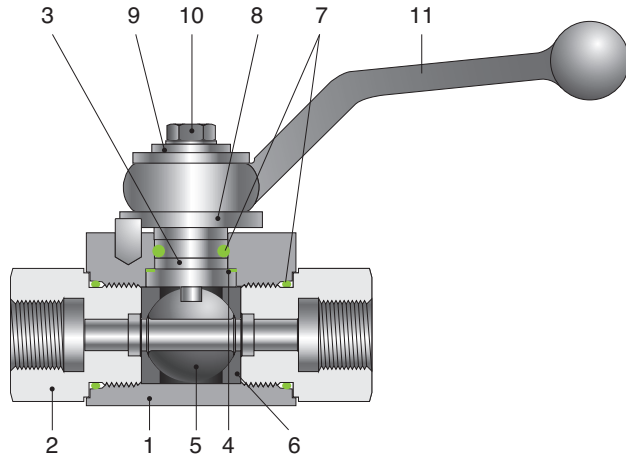
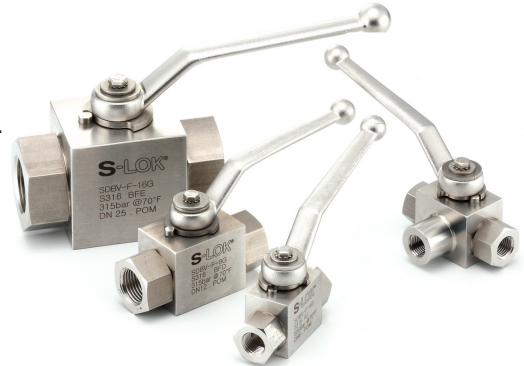

### Materials of Construction

Description		Grade / Specification
1	Body	S316/A479 or A276 DIN 17440/14571
2	End Connector	
3	Stem	
4	Stem Bearing	PTFE
5	Ball	S316/A479 or A276 DIN 17440/14571
6	Ball Seats	POM – MoS2 (Standard)
7	Stem & End Seals	Fluorocarbon FKM O-ring
8	Locking Device	Stainless Steel
9	Upper Washer	Stainless Steel
10	Bolt	Stainless Steel
11	Handle	S316

### Temperature Rating

#### Seals

Materials	Temperature Rating
NBR	-23 °C to 121 °C
FKM	-23 °C to 200 °C
EPDM	-46 °C to 149 °C

#### Ball Seats

Materials	Temperature Rating
POM – MoS2	-30 °C to 100 °C
PTFE	-54 °C to 65 °C

### Test

- Every valve is factory tested with bubble-tight leakage test at both seat and stem packing with nitrogen at 1,000psig (69barg)
- Hydraulic shell test is performed at 1.5 times the working pressure.
- Seats have a maximum allowable leakage rate of 0.1 SCCM Optional tests are available upon request

### Safety in Valve Selection

When selecting a valve, the total system design must be considered to ensure safe, trouble-free performance. Valve function, materials compatibility, adequate ratings, proper installation, operation, and maintenance are the responsibility of the system designer and user.

## Product Information

### Table of Dimensions

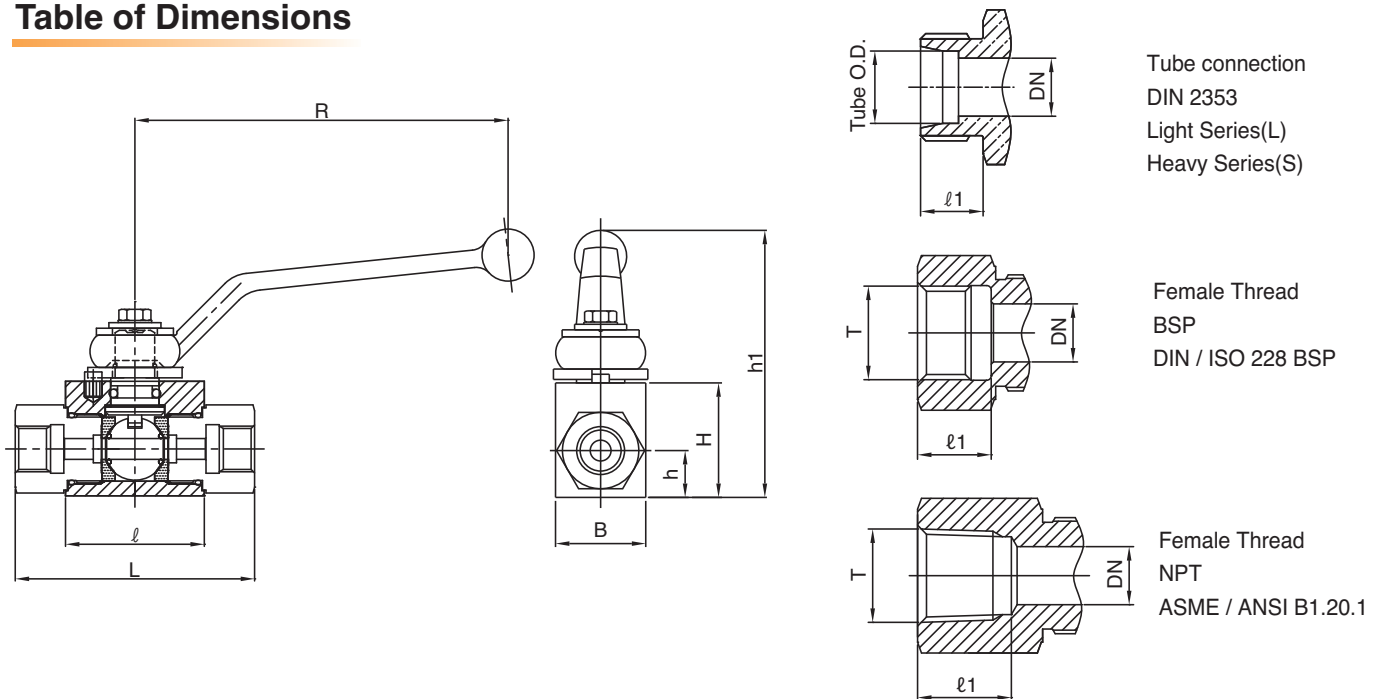

#### DIN 2353 Light(L) Tube Series

Basic Ordering Number	End Connections Inlet & Outlet	DN	PB	Dimensions (mm)								Weight (kg)
				B	H	h	h1	L	ℓ	ℓ1	R	
SDBV1 – 6L	6MM	4	315	26	33	13.5	82	67	40	10	115	0.4
SDBV1 – 8L	8MM	6	315	26	33	13.5	82	67	40	10	115	0.4
SDBV1 – 10L	10MM	6	315	26	33	13.5	82	74	40	11	115	0.5
SDBV2 – 12L	12MM	10	315	32	38	17.5	87	74	43	11	115	0.6
SDBV3 – 15L	15MM	13	315	35	40	19	89	82	48	12	115	0.7
SDBV3 – 18L	18MM	13	315	35	40	19	89	82	48	12	115	0.8
SDBV4 – 22L	22MM	20	160	49	57	24.5	114	101	62	14	159	2.1
SDBV5 – 28L	28MM	25	160	58	65	29.5	122	108	66.2	14	159	2.3
SDBV5 – 35L	35MM	25	160	58	65	29.5	122	112	66.2	16	159	2.3

#### DIN 2353 Heavy (S) Tube Series

Basic Ordering Number	End Connections Inlet & Outlet	DN	PB	Dimensions (mm)								Weight (kg)
				B	H	h	h1	L	ℓ	ℓ1	R	
SDBV1 – 8S	8MM	4	500	26	33	13.5	82	73	40	12	115	0.4
SDBV1 – 10S	10MM	6	500	26	33	13.5	82	73	40	12	115	0.4
SDBV2 – 12S	12MM	6	500	32	38	13.5	82	76	43	12	115	0.5
SDBV2 – 14S	14MM	10	500	32	38	17.5	87	80	43	14	115	0.6
SDBV3 – 16S	16MM	13	400	35	40	19	89	86	48	14	115	0.7
SDBV3 – 20S	20MM	13	400	35	40	19	89	90	48	16	115	0.8
SDBV4 – 25S	25MM	20	315	49	57	24.5	114	109	62	18	159	2.1
SDBV5 – 30S	30MM	25	315	58	65	29.5	122	120	66.2	20	159	2.3
SDBV5 – 38S	38MM	25	315	58	65	29.5	122	124	66.2	22	159	2.3

## Product Information

### Female DIN / ISO 228 / BSP

Basic Ordering Number	End Connections Inlet & Outlet	DN	PB	Dimensions (mm)								Weight (kg)
				B	H	h	h1	L	ℓ	ℓ1	R	
SDBV1-F-2G	PF 1/8	6	500	26	33	13.5	82	68.8	40	10	115	0.4
SDBV1-F-4G	PF 1/4	6	500	26	33	13.5	82	68.8	40	14	115	0.4
SDBV2-F-6G	PF 3/8	10	500	32	38	17.5	87	71.9	43	14	115	0.6
SDBV3-F-8G	PF 1/2	13	500	35	40	19	89	82.3	48	16.5	115	0.7
SDBV4-F-12G	PF 3/4	20	315	49	57	24.5	114	95.4	62	18	159	1.6
SDBV5-F-16G	PF 1	25	315	58	65	29.5	122	112.7	66.2	20	159	2.3
SDBV6-F-20G	PF1 1/4	32	315	75	82	37.5	165	121.6	68	22	260	4.36
SDBV7-F-24G	PF 1 1/2	38	315	95	99.1	47.5	182	130.2	85	24	260	6.8
SDBV8-F-32G	PF 2	50	315	115	115.2	57.5	198	140	100	26	260	9.44

### Female NPT (ANSI/ASME B1.20.1)

Basic Ordering Number	End Connections Inlet & Outlet	DN	PB	Dimensions (mm)								Weight (kg)
				B	H	h	h1	L	ℓ	ℓ1	R	
SDBV1-F-4N	NPT 1/4	6	500	26	33	13.5	82	68.8	40	15	115	0.4
SDBV2-F-6N	NPT 3/8	10	500	32	38	17.5	87	78	43	15	115	0.6
SDBV3-F-8N	NPT 1/2	13	500	35	40	19	89	104	48	20.5	115	0.7
SDBV4-F-12N	NPT 3/4	20	315	49	57	24.5	114	102	62	21.5	159	1.6
SDBV5-F-16N	NPT 1	25	315	58	65	29.5	122	119	66.2	25.4	159	2.3
SDBV6-F-20N	NPT 1 1/4	32	315	75	82	37.5	165	-	68	-	260	-
SDBV7-F-24N	NPT 1 1/2	38	315	95	99.1	47.5	182	-	85	-	260	-
SDBV8-F-32N	NPT 2	50	315	115	115.2	57.5	198	-	100	-	260	-

## Applications

- Hydraulic fluids, compressed air, lubricants, and fuel oil system.

## Sour Gas Service

- Is provided to meet NACE Standard MR0175.

## Ordering Information

- Selection of the applicable options from the designators are listed below.

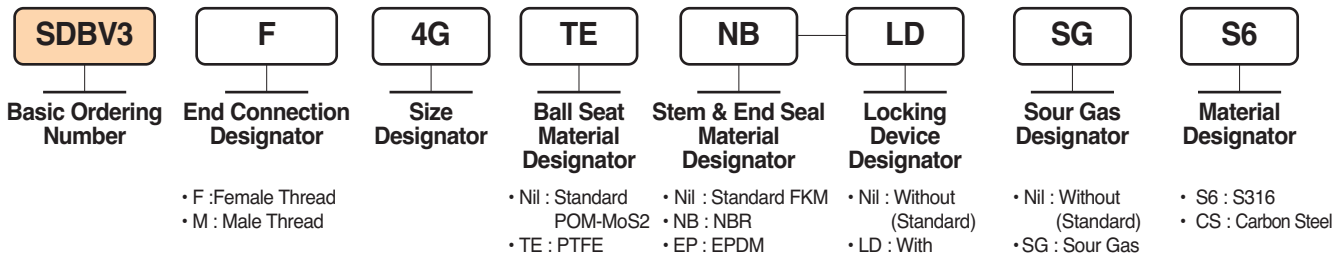

## SPV Series Plug Valves

### Features

- Pressure rating up 3,000psig(206barg) @70°F(21°C)
- Temperature rating from -10 °F to 400°F(-23°C to 204°C) with PTFE coated Viton Seal
- Small and compact design
- Easy maintenance and cleaning
- Sizes available up to 1/2" tube and pipe
- Body materials available in 316 stainless steel and brass



### Material of Construction

Component	Valve Body Materials	
	Stainless Steel	Brass
	Grade/ASTM Specification	
1. Body	S316/ A479 or A276	Brass / B16
2. Plug	PTFE-coated S316/ A479 or A276	PTFE-coated Brass / B16
3. O-ring	PTFE-coated Viton Standard	
4. Handle	Nylon	
5. Pin	S316/A276	
6. Snap ring	Stainless Steel	

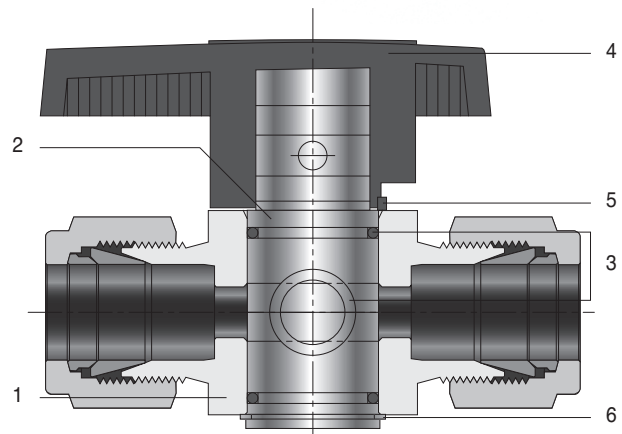

- Wetted parts and lubricants listed in Red.

### Pressure-Temperature Rating

Series	Valve Material	Pressure Rating		Temperature Rating	Plug Orifice mm (in.)
		Psig	Barg		
SPV1	S316	3,000	206	-10 to 400 °F (-23 to 204 °C)	4.4 (.17)
	Brass				
SPV2	S316	2,000	137		7.2 (.28)
	Brass				

- Differential pressure is limited to maximum 150 psig (10.3barg) when reverse flow occurs.
- Throttling reverse flow may damage O-ring.

### Testing

- Every valve is factory tested for shut off at 600psig (41barg)

### Optional O-ring Material

O-ring material	Temperature Range
Standard PTFE - coated Viton	-20 to 400°F(-28 to 204°C)
PTFE - coated NBR	-68 to 221°F(-20 to 105°C)
PTEF - coated EPDM	-49 to 275°F(-45 to 135°C)

- PTFE - coated Viton is standard. Choose optional O-ring material for fluid compatibility and system temperatures.

## Product Information

### Ordering Information and Dimensions

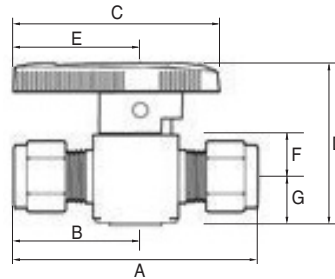

Basic Ordering Number	End Connections		Dimensions mm (inches)							
	Inlet	Outlet	A	B	C	D	E	F	G	H
SPV1	S-2T	1/8 S-Lok	50.5 (1.99)	19.8 (0.78)	47.8 (1.88)	38.6 (1.52)	29.0 (1.14)	9.4 (0.37)	11.7 (0.46)	19.1 (0.75)
	S-4T	1/4 S-Lok	55.1 (2.17)							
	S-6T	3/8 S-Lok	58.2 (2.29)							
	S-6M	6mm S-Lok	55.1 (2.17)							
	M-2N	1/8 M NPT	38.9 (1.53)							
	M-4N	1/4 M NPT	48.3 (1.90)							
	MS-4N4T	1/4 M NPT   1/4 S-Lok	51.2 (2.03)							
	MF-4N	1/4 M NPT   1/4 F NPT	50.8 (2.00)							
	F-2N	1/8 F NPT	45.2 (1.78)							
	F-4N	1/4 F NPT	53.1 (2.09)							
F-4R	1/4 F ISO tapered	56.1 (2.21)								
SPV2	S-6T	3/8 S-Lok	67.6 (2.66)	29.0 (1.14)	63.2 (2.49)	54.1 (2.13)	38.1 (1.50)	14.2 (0.56)	16.8 (0.66)	28.4 (1.12)
	S-8T	1/2 S-Lok	73.2 (2.88)							
	S-8M	8mm S-Lok	67.6 (2.66)							
	S-10M	10mm S-Lok	68.1 (2.68)							
	S-12M	12mm S-LOK	75.2 (2.96)							
	M-8N	1/2 M NPT	67.1 (2.64)							
	F-6N	3/8 F NPT	60.5 (2.38)							
	F-8N	1/2 F NPT	73.2 (2.88)							
F-8R	1/2 ISO F Tapered	79.8 (3.14)								

### Operation

- S-LOK plug valves provide positive shut-off, high flow capacity, and quick quarter-turn operation.
- S-LOK plug valve provides flow throttling capability.

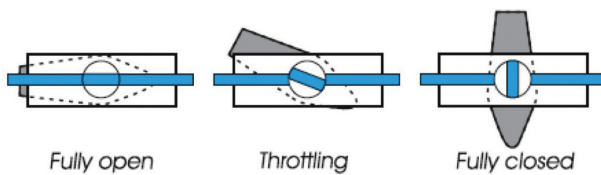

### Downstream Vent

- S-LOK plug valves provide positive shut-off, high flow capacity, and quick quarter-turn operation.
- S-LOK plug valve provides flow throttling capability.

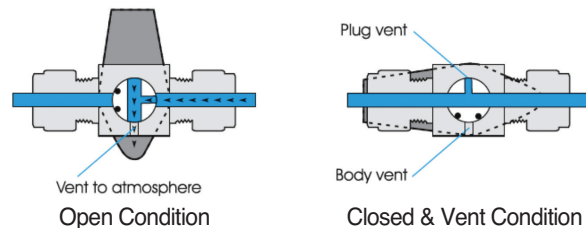

## Product Information

### Flow Rate

Basic Ordering Number	End Connections		Cv	Pressure Drop in the Atmosphere, psi (bar)						
	Inlet	Outlet		Air Flow, std ft <sup>3</sup> /min (L/min)			Water Flow, US gal/min(L/min)			
				@70 °F (21 °C)						
				1 (0.068)	5 (0.34)	10 (0.68)	1 (0.068)	5 (0.34)	10 (0.68)	
SPV1	S-2T	1/8 S-Lok	0.1	0.3 (8.4)	0.8 (22)	1.1 (31)	0.1 (0.37)	0.2 (0.75)	0.3 (1.1)	
	S-4T	1/4 S-Lok	1.6	6.0 (169)	13 (368)	18 (509)	1.6 (6.0)	3.6 (13.6)	5.1 (19.3)	
	S-6T	3/8 S-Lok	1.1	4.1 (116)	8.9 (252)	12.4 (351)	1.1 (4.1)	2.5 (9.4)	3.5 (13.2)	
	S-6M	6mm S-Lok	1.6	6.0 (169)	13 (368)	18 (509)	1.6 (6.0)	3.6 (13.6)	5.1 (9.3)	
	M-2N	1/8 M NPT	1.0	3.7 (104)	8.1 (229)	11.3 (320)	1.0 (3.7)	2.2 (8.3)	3.2 (12.1)	
	M-4N	1/4 M NPT								
	MS-4N4T	1/4 M NPT	1/4 S-Lok	0.9	3.3 (93)	7.3 (206)	101 (286)	0.9 (3.4)	2.0 (7.5)	2.8 (10.8)
	MF-4N	1/4 M NPT	1/4 F NPT	1.0	3.7 (104)	8.1 (229)	11.3 (320)	1.0 (3.7)	2.2 (8.3)	3.2 (12.1)
	F-2N	1/8 F NPT		1.2	4.4 (124)	9.7 (274)	13.5 (382)	1.2 (4.5)	2.7 (10.2)	3.8 (14.3)
	F-4N	1/4 F NPT		0.9	3.3 (93)	7.3 (206)	10.1 (286)	0.9 (3.4)	2.0 (7.5)	2.8 (10.8)
F-4R	1/4 F ISO tapered									
SPV2	S-6T	3/8 S-Lok	6.4	23.9 (676)	52.0 (1,470)	72.3 (3,040)	6.4 (24.2)	14.3 (54.1)	20.2 (76.4)	
	S-8T	1/2 S-Lok	4.4	16.4 (464)	35.7 (1,010)	49.7 (1,400)	4.4 (16.6)	9.8 (37.0)	13.9 (52.6)	
	S-8M	8mm S-Lok	6.4	23.9 (676)	52.0 (1,470)	72.3 (2,040)	6.4 (24.2)	14.3 (54.1)	20.2 (76.4)	
	S-10M	10mm S-Lok								
	S-12M	12mm S-LOK	4.8	17.9 (506)	39.0 (1,100)	54.2 (1,530)	4.8 (18.1)	10.7 (40.4)	15.2 (57.5)	
	M-8N	1/2 M NPT	2.4	9.0 (254)	19.5 (552)	27.1 (767)	2.4 (9.0)	5.4 (20.4)	7.6 (28.7)	
	F-6N	3/8 F NPT	4.3	16.0 (453)	34.9 (988)	48.6 (1,370)	4.3 (16.2)	9.6 (36.3)	13.6 (51.4)	
	F-8N	1/2 F NPT	2.7	10.1 (286)	21.9 (620)	30.5 (863)	2.7 (10.2)	6.0 (22.7)	8.5 (32.1)	
	F-8R	1/2 ISO F Tapered								

### Ordering Information

- Select the desired valve's basic ordering number, option and body material.

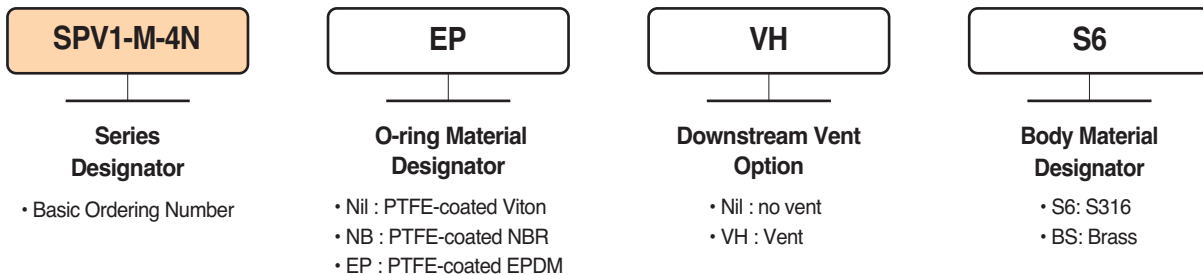

### Safe Valve Selection

- The selection of a valve for any application or system design must be considered to ensure safe performance. Valve function, valve rating, material compatibility, proper installation, operation and maintenance remain the sole responsibility of the system designer and the user. S-LOK accepts no liability for any improper selection, installation, operation or maintenance.

